

INSTALLATION INSTRUCTIONS FOR SENTREL VERTICAL CABLE BALUSTRADES & POOL FENCING

Sentrel will take NO RESPONSIBILITY for problems arising from installations that are not in accordance with our instructions

Introduction

Congratulations on your purchase of Sentrel balustrades or pool fencing. Our products are engineer certified and comply with the relevant Australian standards. Sentrel vertical cable balustrade and pool fencing comes as pre-made panels ready for installation. Mounting posts will either be existing, or will need to be fitted before installing the panels. They will need to be structurally sound and the correct height.

Panels have been supplied to you slightly oversize of the corresponding openings between posts. Installation is simple and primarily all that is required is to trim the panels to size, and fit to the posts using the mounting pins provided.

The following instructions are thorough and will guide you through the installation process for mounting **balustrade** panels. The process is also similar for **pool fencing**, the main difference being that pool fencing finishes at 1205mm high rather than the 1005mm finished height for balustrade. Other differences are noted in the text in [blue print](#). We advise that you read through these instructions completely before beginning to assure understanding of the process and to achieve the best results.

What you will need

You will need:

- Drop saw
- Measuring tape
- Drill/Driver with ½ inch (12.7mm) dowel drill and batten screw driver
- Hammer
- AV 515 adhesive
- Knife
- F Clamps
- Stainless steel cleaner
- 75mm batten screws
- Mounting pins (supplied)

You may also need:

- Biscuit joiner and biscuits
- ½ inch chisel
- 17mm socket and ratchet
- Ratchet straps

Preparing posts for mounting panels

- Run a string line connecting the posts at 970mm off the deck from the highest point of the deck. **Note: Many decks are not level and the finished height of the balustrade off the deck must be no less than 1 metre (The 970mm measurement allows for the fitting of 35mm thick handrail supplied to give a finished height of approximately 1005mm). If you run a string line horizontal from a low point of the deck, you will finish up with the balustrade being under regulation height at the higher points of the deck.**
- Accurately mark the posts off the string with a square, or if handrail is to run over the tops of the posts, mark and cut the posts neat and square
- Mark the position of the mounting pins by measuring down the centre line of the post 50mm and 875mm from the string line mark (or top of the cut post). **(Dia.1)** Alternatively, if all the panels are to run *between* the posts only (ie; handrail does not run over the top of the posts), simply run a string line at 920mm marking the top pin position, and then measure down 825mm to mark the bottom pin position. **Note: Accuracy at this stage is vital and affects the ease of installation and quality of the finished product. The top pin positioning determines the finished height of the balustrade, and both top and bottom pins determine the line. If pin position varies, so will the line of the balustrade.**
- For **pool fencing** where *capping runs between the posts*, posts must first be positioned so that the top of the post finishes 1250mm above the finished ground (or deck) height. Run a string line connecting the posts at 1130mm off the ground/deck (measured from highest point as mentioned above) to mark the top pin position and then measure down a further 1025mm (1075 from top of post) to mark the bottom pin position
- For **pool fencing** where *handrail runs over the top of the posts*, posts must finish 1170 off the ground/deck (measured from highest point as mentioned above). Then measure down 50mm from top of post to mark the top pin position and then measure down a further 1025mm to mark the bottom pin position

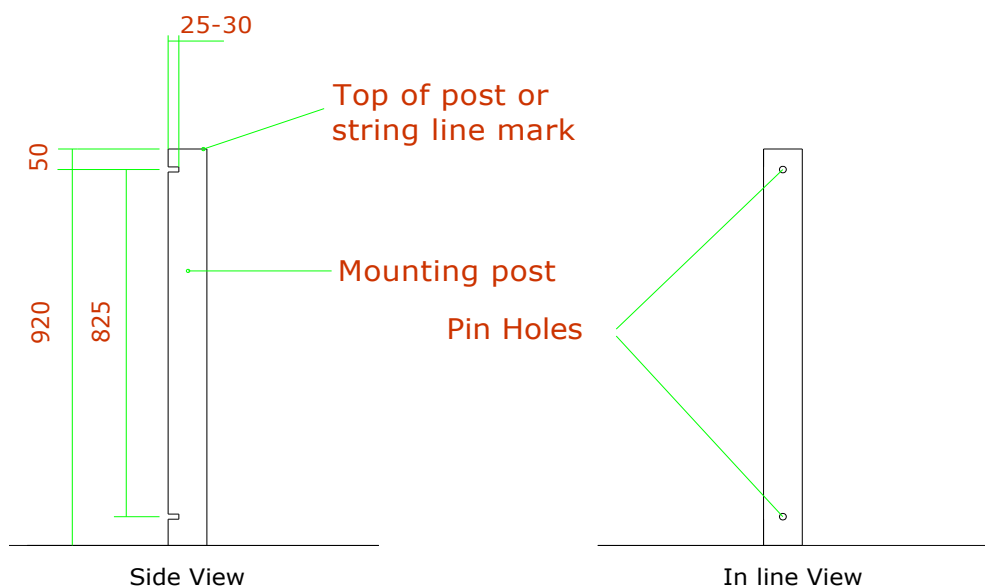

Diagram 1

- Using a ½ inch (12.7mm) dowel drill, drill holes horizontally about 25 – 30mm deep. Alternatively, drill a pilot hole, then a ½ inch (12.7mm) hole with a twist drill (if a pilot hole isn't used the ½ inch drill may tend to wander and result in incorrect positioning of the pins. Using a dowel drill gives the best results)
- Hammer the mounting pins provided into the holes. If the pins are not a firm fit in the holes, use a small amount of adhesive also

Mounting panels

- Match the panels to the corresponding gaps between the posts. The correct panel for the gap is the one that is slightly larger than the corresponding gap (up to 128mm longer, but no more). Because the panels are timber, one side may look better than the other. Consider the 'best' side and its position when mounting panels.
- Taking one panel at a time, and beginning from one end, measure the gap between the posts accurately both top and bottom where the mounting pins are. (Posts may be skewed or not parallel and this will need to be compensated for by cutting the top rail and bottom rail to suit. For the best job, every effort should be made to correct the posts rather than adjusting the rails). **(Dia. 2)**

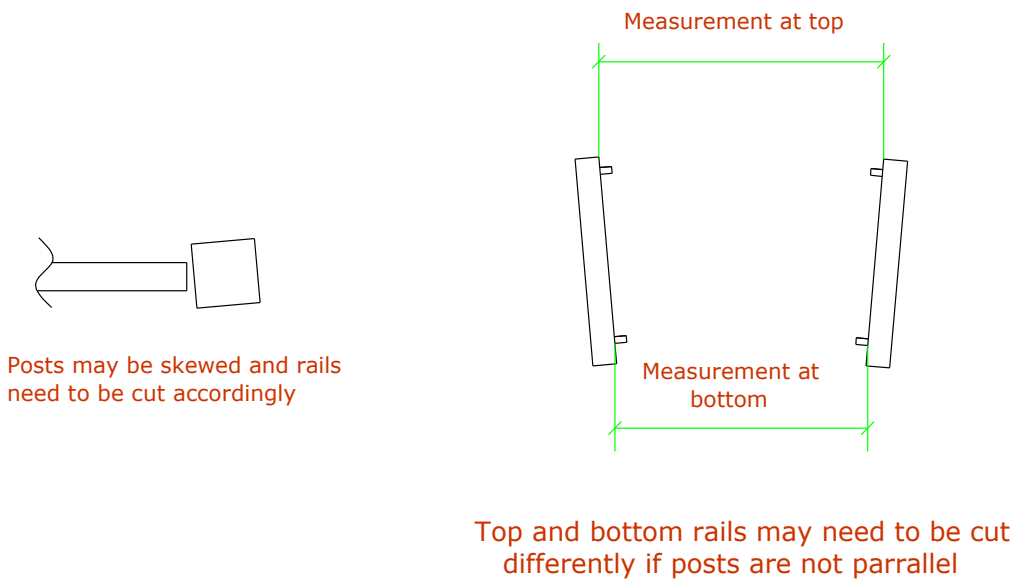

Diagram 2

- Measure the panel rails
- Subtract the gap measurement from the rail measurement. Divide the answer by 2, measure this distance in from the end of each rail, and trim the rail to this mark using a drop saw. Eg; if the gap is 2040mm, and the panel is 2100, then subtract 2040 from 2100 = 60mm. Divide 60 by 2 = 30mm. Mark 30mm in from both ends of the rail, and trim off this amount (**Dia. 3**). Accuracy at this point is vital. Inaccurate measurement will result in gaps between the posts and the balustrade, and this affects appearance and quality of the product. **Note:** It is advisable to cut one end of the panel rails first, then measure back to the mark at the other end of the rail just to double check that it is the same measurement as the gap.

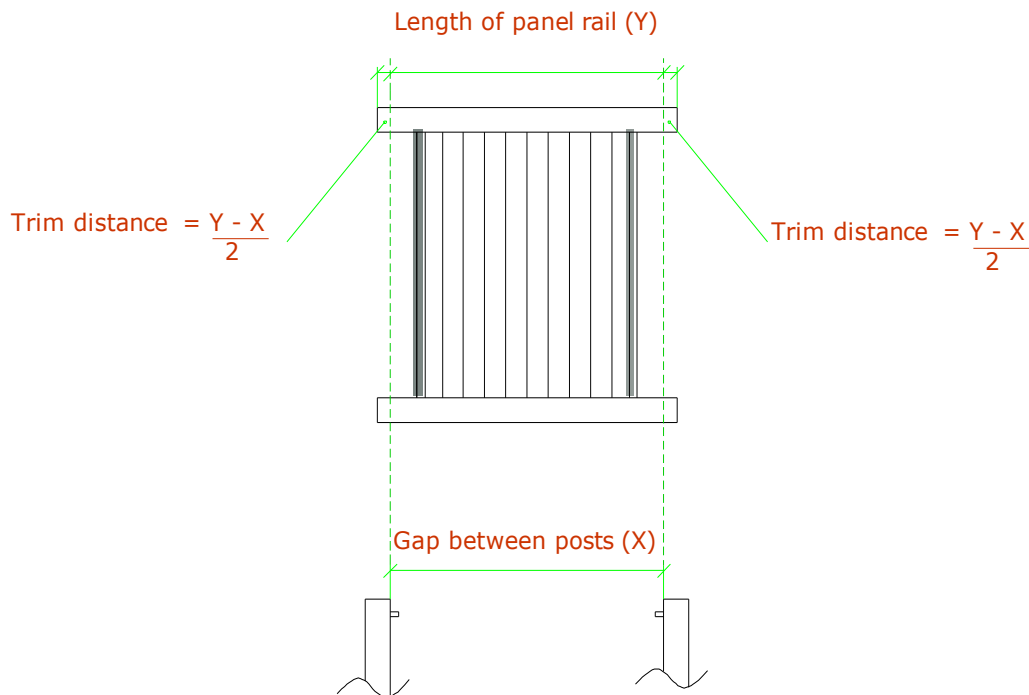

Diagram 3

- Panel will now fit over and onto the pins. **Note:** In some cases, (e.g. when panels run between posts and posts are not sufficiently rigid, or need pulling in, or on unsupported corner posts) it will be necessary to fix the top rail to the post to stop the post moving away from the panel. This is achieved by clamping (strapping) the posts and panels together (so there are no gaps between the end of the rails and the post) then drilling a 6mm countersunk hole skewed through the top at the end of the rail and into the post, then screwing a 75mm batten screw into the hole. **Note:** Ensure that top of the top rail remains 5 mm above the top of the post or string mark. Screws must be offset from centreline of rail otherwise they will hit the mounting pin
- **NOTE: ALWAYS MOUNT ONE PANEL FIRST TO CHECK THAT ALL PINS, HEIGHTS, ETC ARE CORRECT BEFORE DRILLING THE REMAINING HOLES**
- Repeat this process for the remaining panels. **Note: NEVER FIX THE BOTTOM RAIL WITH SCREWS. The bottom rail must be able to 'float' to allow for re-tensioning of the cables over time if necessary. See [re-tensioning video](#)**

Fitting the Handrail

- Check that the top line of the balustrade is straight and level. If not, make good before fixing handrails. Small adjustments can be made by packing under the pins to raise the height, or by chiselling out the mounting slot to lower the height. If all top mounting pins have been accurately placed, there should be no need for adjustment.

If handrails run between posts;

- Simply measure the gap and dock the handrails provided to length. **Note: Bevel cutting may be required - as with the panel rails - if posts are skewed**
- Place handrail over top rail, and fix using 75mm batten screws through the predrilled holes in the underside of the top rail. **Note: To avoid splitting, it is imperative to drill a 5mm pilot hole first and screw the batten screws in gently.**

If handrails run over the top of the posts;

- Make sure that all the posts are pulled in against the panels. This can be achieved by running a strap around the whole length of the balustrade, and tightening.
- The top rail of the balustrade panels will sit 5mm above the top of the posts. This allows the handrail, which has a 5mm channel underneath, to sit over the top rail and neatly onto the top of the mounting posts (**Dia. 4**) If this measurement is higher or lower, adjust accordingly

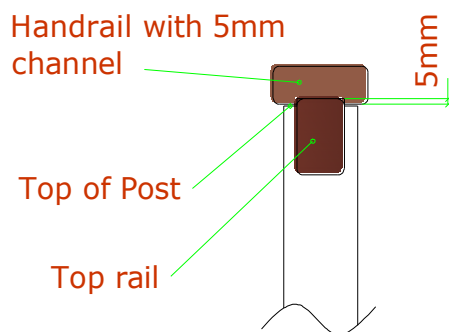

Diagram 4

- Check that the line of the balustrade is straight and level. If not, adjust accordingly
- Using the handrail provided, cut and fit to the top rail of the balustrade. Butt joints along the straights are sufficient, and good neat mitre joints are necessary on the corners. Using a biscuit joiner, cut biscuit slots at each joint. **Note:** joints should not occur over the top of the posts, and at least 100mm clear of any handrail mounting screws (**Dia. 5**)

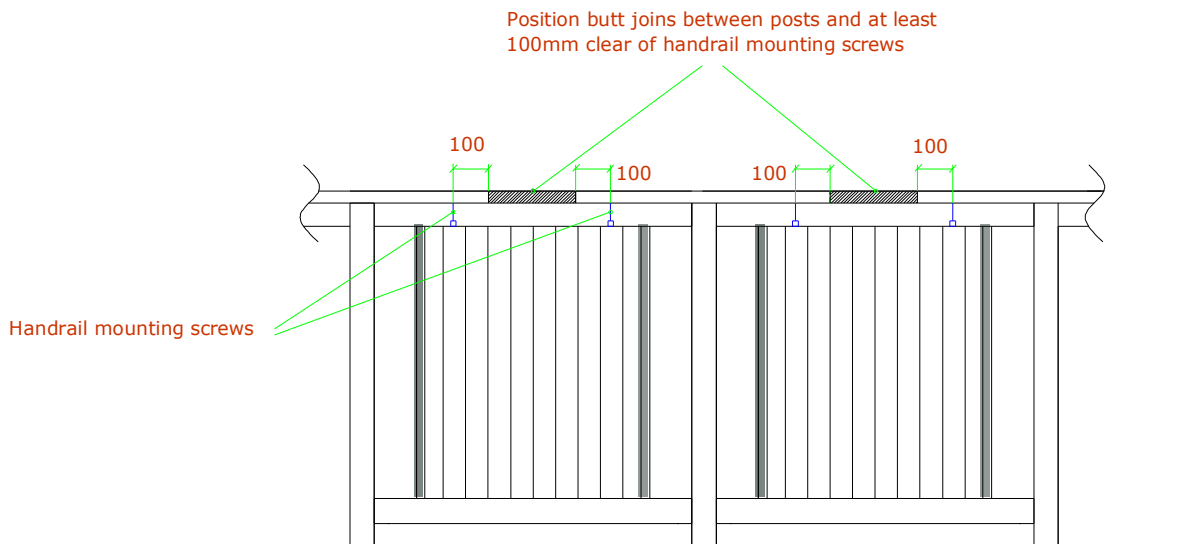

Diagram 5

- Apply a good amount of AV 515 adhesive in the biscuit joins. Assemble handrail on top of top rail, and fix using 75mm batten screws through the predrilled holes in the underside of the top rail. **Note: Drill a 5mm pilot hole first and screw the batten screws in gently.**
- Allow glue to set (about 1 hour, more is better) and trim off excess. Sand if necessary, then oil.

Checking Cable Tension

Check online www.sentrel.com.au/technical.html for an easy to follow video, or follow the instructions below

- The tension in the cables is preset in the factory and should not require any tensioning. It is a good idea, however, to check using the tension gauge provided.
- First, make sure all the cables in any one segment of the balustrade have uniform tension (each segment – the area between the supporting upright poles - incorporates one continuous cable woven back and forth between the upper and lower rails). Push on the cables and 'chase' the tension around from the loosest cable to the tightest, until all cables feel similar in tension. Cables will sound similar in tone if plucked when the tension is uniform.

sentrel

- Now test the tension with the gauge provided (**Dia. 1**) by putting it through between any two cables approximately half way between the upper and lower rails (**Dia. 2**)

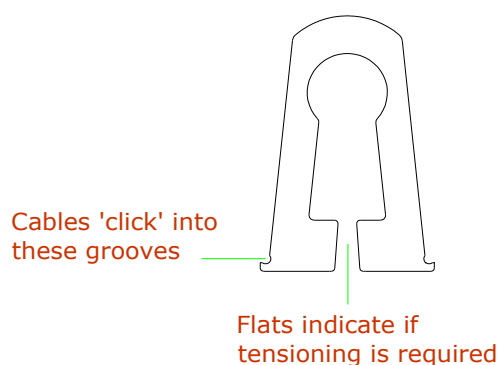

Tension testing gauge

Diagram 1

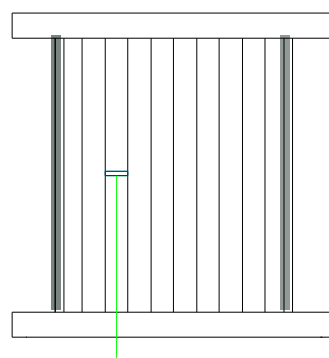

Use the gauge half way between the upper and lower rails

Diagram 2

- Turn the gauge so that it is horizontal and pull it towards you until the cables ‘click’ into the grooves at the back of the gauge. If the flats on the gauge close, the tension is OK. If the gaps do not close, the cables are loose and will require re-tensioning. Test a number of the cables, and re-tension if necessary by tightening the bolts in the bottom rail under each stainless upright an equal amount. The tool required to do this is a 17mm socket. **Note:** Do not over tighten as this may cause the timber rails to bend under the strain. **Please leave the tensioning gauge with the client and instructions so that they will be able to check the tension over time**
- Because timber will tend to settle into its environment, it is important to check the tension after approximately two months of initial install, and thereafter annually.
- GATES use an inline tensioner located at the end of a cable run in the bottom rail. To re-tension a gate, ‘chase’ the tension up toward the end incorporating the tensioner, and unscrew the tensioner bolt to take up the slack

Finishing up

- Clean down stainless steel uprights with a suitable cleaner – White Spirit is ideal. Protect with Nano Coat Metal 2 in 1, if your balustrade is in a aggressive environment (eg. near the ocean)
- **Stand back and admire your handiwork, and the beautiful new balustrade!**

Note: The timber has been oiled in the factory. To keep the balustrade looking its best, it is recommended to recoat with a good quality exterior timber/decking oil within a few months of installation, then 6 months after, and then annually thereafter. If timber is left unoiled, it will silver with age, however this will not affect performance, and in many cases is, in fact, a desirable look requiring no maintenance.

If you have installed a gate with hinges supplied by us, please note that these hinges are ADJUSTABLE! Set to the lowest setting possible to close the gate without slamming.

sentrel

INSTALLATION INSTRUCTIONS FOR STAIR PANELS

- Hold (clamp) the stair panel in position at the correct angle, and centred between the mounting posts. Ensure that the upright poles are vertical and parallel with the mounting posts (**Dia. 1**). It is more important that the poles are parallel with the posts than the panel rails being parallel with the nosing line if there is a discrepancy between the two. The panel must be also positioned so that when the handrail is fitted the measurement from the top of the handrail to the nosing line is no less than 865mm (**Dia. 1a**)
- Loosen off tensioning bolts in bottom rail to assist in fitting if necessary
- Ensure panel is at correct height, i.e;
 - Top of handrail to nosing line to be no less than **865 mm (Dia. 1a)**
 - Must be a minimum of **50 mm** gap above the nosing line (or stringer) so that re-tensioning of the cables is possible
- Mark (on the post) where the top of the top rail and the bottom of the bottom rail meet the mounting posts (**Dia. 2**)
- Mark (on the stair panel) where the top and bottom rails intersect with the mounting posts
- Remove panel and trim on the marks. **Note:** Accuracy at this point is vital. Mismeasurement will result in gaps between the posts and the balustrade, and this effects the appearance and quality of the product

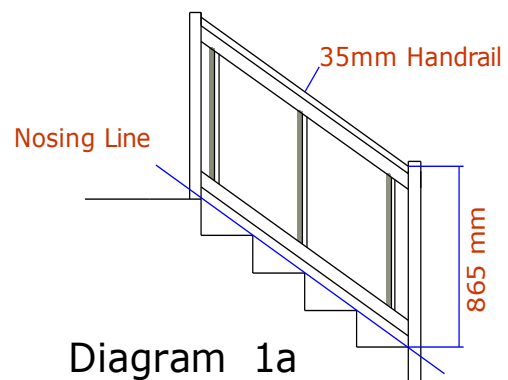
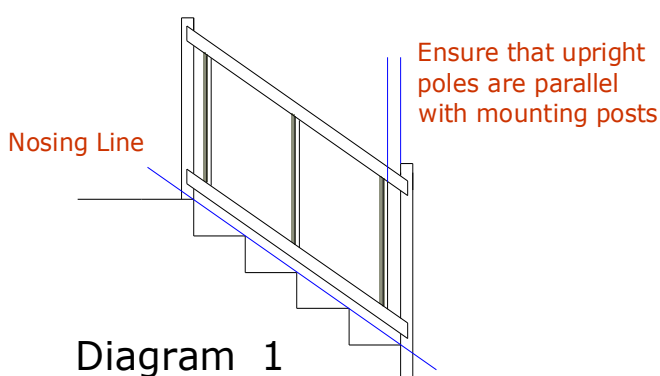

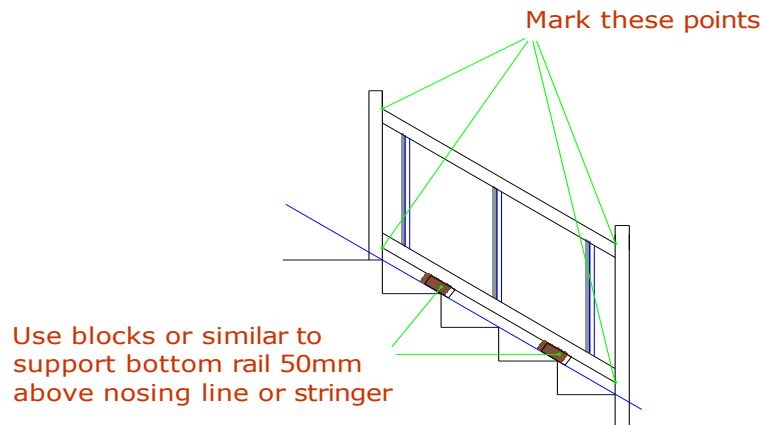

Diagram 2

Mounting the Panel

- Measure up 10 – 15mm from the bottom rail mark made on the post.
- Using the dowel drill, drill a hole in line with the nosing line on the centre line of the post 30mm deep (**Dia. 3**)

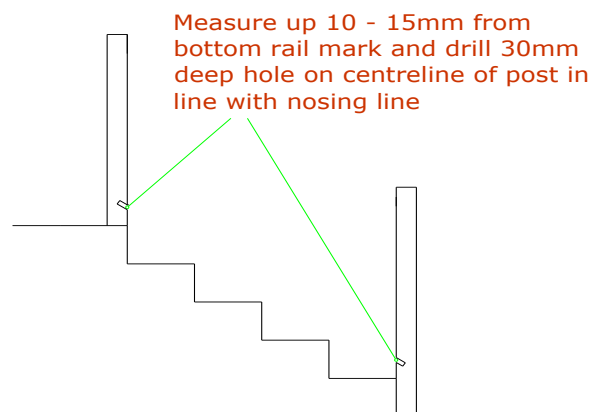

Diagram 3

- Hammer (and glue if necessary) the mounting pins provided into the holes
- If handrail is to run over the top of posts, measure down from the mark where the top rail meets the posts the required distance so that when cut, the plane of the top of the post is 5mm below the line of the top of the top rail (**Dia. 4**) This is so the channel in the top rail will sit over the top rail and onto the top of the post

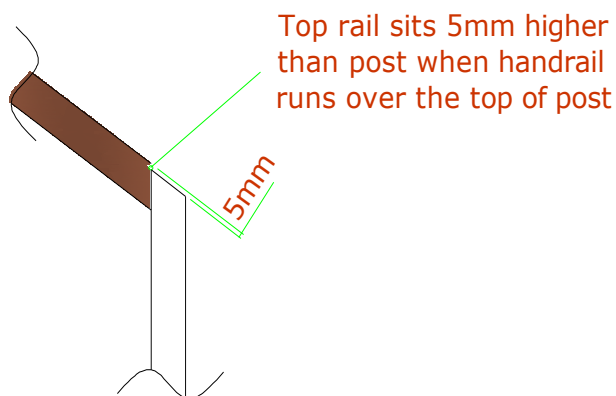

Diagram 4

- Cut the post neatly and accurately at the correct angle
- Place panel between posts and over the bottom mounting pins
- Using clamps or similar, devise a way to raise and fine tune the position of the top rail so that it meets with the mark, or correct position 5mm above the top of post if handrail is to run over
- Fix top rail in position by skew screwing through from the top into the posts. Drill clearance holes to avoid splitting the timber and make sure that any gap closes between the rail and post. Be sure that the rail remains on its mark (it may be necessary to use straps to hold everything in place while gluing and fixing)
- NEVER FIX BOTTOM RAIL WITH SCREWS
- Fit the handrail over the top rail with adhesive, and clamp until set. Trim off any excess glue with a sharp knife.
- Tension cables if necessary